

What's New in NX 8

Leading CAD/CAM/CAE maximizes product development productivity and helps you get the right product to market faster than ever before

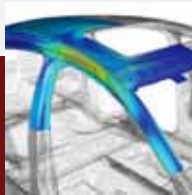

NX

Swoosh
Technologies & Solutions, L.L.C.

What NX 8 can do for You

NX 8 for Design:

NX 8 will refine productivity and accelerate your design process with new and improved tools in NX 8. The expanded High Definition (HD3D) support is easier for you to create and customize reports to include data from throughout the enterprise; HD3D has also been extended in NX validation and template creation tools, allowing you to diagnose problems and identify issues faster. NX 8 brings you more powerful and efficient modeling, drafting, validation, and more.

NX 8 for Simulation:

NX 8 will reduce the time you spend preparing and solving analysis models by up to 70 percent. You can rapidly build, update and simulate analysis models, make smarter engineering decisions and deliver better products faster.

NX 8 CAE offers new solutions for your optimization and multi-physics analysis, along with new methods for analyzing your complex assemblies.

NX Nastran 8 contains improvements for your nonlinear and dynamic analysis and increases in computational performance and modeling ease-of-use.

NX 8 for Manufacturing:

NX 8 will redefine your part manufacturing with new or extended capabilities in design. It delivers optimized NC programming for your machinery and heavy equipment part production. With the latest developments in NX, your tooling design combines design automation with CAE-based validation tools to help you deliver “right-first-time” designs and win more high value projects.



SIEMENS

The NX 8 product development solution from Siemens PLM Software delivers new capabilities and more powerful tools for design, simulation and manufacturing. The latest release builds on Siemens' high-definition PLM technology framework to provide more visual information and analytics that improve collaboration and decision-making. Customer-driven enhancements for CAD modeling, validation, drafting, simulation/CAE, tooling design and machining boost productivity throughout product development to help companies deliver higher quality products faster and at lower costs.



High-definition 3D

NX 8 includes many extensions of high-definition PLM technologies for product development. The high-definition 3D (HD3D) environment and visual reporting and analytics tools in NX have been expanded to enable rich visual interaction and information delivery for validation, product templates and other applications.

HD3D Visual Reporting in NX 8 expands the number and scope of predefined, out-of-the-box reports, providing more information about on-time/late status and other design and project properties. You can also create multi-dimensional reports that include more than one top-level report property, enabling you to color code objects by one property and display visual tags for other properties for richer visual feedback – for example, color code parts by tooling status while displaying tags on the parts for completion schedule. You can switch among the top-level report properties in order to group and sort reported data in different ways.

Predefined reports from Teamcenter 9 Report Builder convey information on parts affected by change orders, change requests or problem reports; part status in change process or workflow; and components with higher revision levels. You can create additional reports with Teamcenter 9 Report Builder to gather and report other data of interest from Teamcenter or external data sources.

Enhanced input methods and usability allow easier creation of visual reports that cover a wider and more complex set of queries. New support for date type values, lists of valid values, type-in completion, and Teamcenter properties streamline report definition. HD3D Visual Reporting also supports custom bitmaps and legends, custom InfoView and tooltip information, and hyperlinks to websites and associated documents to enhance visual feedback.

Validation: The NX Check-Mate validation checking tool has been extended in NX 8 to encompass more than 300 out-of-the-box checkers and 900 checking functions. These now include all geometric quality criteria defined in the Strategic Automotive Product Data Standards Industry Group – Product Data Quality guidelines. Improvements in the HD3D user interface to Check-Mate deliver richer visual interaction that accelerates comprehension and resolution of problems.

Requirements validation: With NX 7.5, Requirements Validation was expanded with the capability for allocating Teamcenter requirements to product subsystems and attaching them to NX designs. In NX 8, Requirements Validation has been enhanced with HD3D interactions for requirements check creation, results and notifications. Using standard HD3D features like flow lists, visual tags, InfoView, tooltips and see-through display modes, Requirements Validation now provides a visually rich and more flexible feedback environment that helps you to quickly locate, diagnose and fix problems to ensure that products fulfill their requirements.



NX for design productivity

Modular design: NX introduces a modular design capability that simplifies modeling and editing of complex designs, and enables parallel work by multiple designers. With part modules, you can subdivide designs into isolated, self-contained functional elements with modular interfaces in an organized structure of re-usable design elements with embedded intelligence.

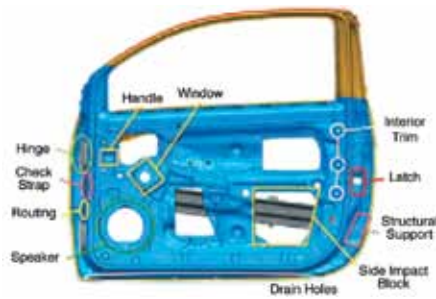

Feature-based modeling: A new feature browser provides a visually rich graphic view of features and their relations that helps you to more quickly and intuitively understand design intent and the impacts of design changes. When you roll over a feature in the browser, the object highlights in the graphics window and in the part navigator and relations with other features and objects are displayed.

NX 8 adds the capability to select objects from the Part Navigator as input to active modeling commands. Especially with complex parts, you can frequently select items more quickly and easily from the Part Navigator than from the graphics window.

For creating patterns of features, NX 8 delivers enhanced flexibility and control. You can now create patterns with a wider selection of layouts that included linear, polygon, along, reference, circular spiral or general options. You can also fill a specified boundary with a pattern feature, create symmetric patterns in linear layout, stagger columns or rows and radiate patterns in circular or polygon layouts. Additional controls enable you to define orientation, and select individual instances for clocking, suppression and variance.

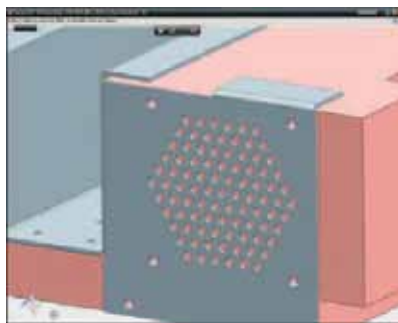

Synchronous Modeling: The fourth release of NX featuring synchronous technology, NX 8 includes improved synchronous modeling capabilities that improve modeling flexibility and enable evaluation of more design alternatives in less time. You can now change the order of intersecting blends of opposite convexity in parts with or without a feature history. When deleting faces of a model, you can optionally heal or not heal neighboring faces. Face modifications in synchronous modeling can now result in higher-quality, curvature-continuous extended surfaces, and you can pull or offset portions of faces limited by curves. The usability of move face operations is enhanced with controls for the direction and location parameters directly in the graphics window instead of in dialog boxes. Interpart selection is enhanced in many commands to simplify modeling with references and links to other parts.



Freeform modeling: NX 8 enhances freeform design with streamlined workflows and enhanced controls for a wide range curve and surface operations, including edge matching, sweeping, bridge and extension surfaces, variable offsets, curve fitting and alignment, blending and spline editing. Face and edge blending now support conic blends, a more advanced type with a soft appearance that helps improve the aesthetic quality and formability of cast and sheet metal parts. You can now create draft analysis objects for faces and facet bodies, with color legends indicating areas above and below draft and draft limits.

Assembly Design: NX 8 features a constraint navigator that makes it easier to find and work on assembly constraints and resolve issues. Available from the resource bar, the constraint navigator displays configurable columns of information and options that enable you to group constraint information by components, by constraints, and by status. Fix and bond constraints have been added to hold components in

place. The Assembly Navigator has been enhanced with new icons for unsolved assembly constraints that clearly indicate the nature and severity of problems and provide faster access to additional information.

Routed Systems Design: Routing applications in NX 8 help you automate part selection and placement to reduce modeling time. You can automatically select and place parts based on destination characteristics and run definition, with part search criteria based on defined rules and relationships. The latest release also adds duct size calculators for HVAC ducts based on flow parameters, and a pipe production length checker and calculator that determines shrinkage compensation and the appropriate bend machine.

New routing checks have been implemented in NX 8 that test the validity of routing connections and displays the results. You can set up the checks using the NX Check-Mate validation tools or by configuring a callback with customized conditions and parameters. A visual display of results with graphic tags can be viewed in Check-Mate or HD3D visual reporting, with results filtering by status to quickly identify and correct issues.

Sheet Metal Design: Sheet metal design in NX 8 is improved with capabilities for modeling in the context of an assembly. You can now create associative flanges using existing geometry to control the extent and angle of the flange. When converting solid models to sheet metal models,

you now have the option preserve sharp edges with zero bend radius. Export of flat patterns to DXF file formats has been enhanced with more sheet metal-specific options. Creating punch patterns for sheet metal components is streamlined by leveraging the new pattern modeling tools in NX 8.

Re-use: The NX Reuse Library, a common platform for all re-usable design elements, has been enhanced with additional library management tools that enable you to add or remove libraries, edit properties, control the visibility and specify which libraries are available to NX applications. The Reuse Library now also accommodates re-usable objects with spreadsheets that include part attributes, expressions and locations of preview images. The fastener assemblies library can now be customized with your company's parts or part families as standard fasteners.

NX Product Template Studio, a tool for creating templates from existing models, has been expanded with coverage for additional NX capabilities. With the enhancements, you can now create templates with custom interfaces that include optimization studies, requirements checks, additional validation, routing placement controls, HD3D tags, material selection, help tags and other information. New visual rules have been added and support for multi-byte languages has been improved.

Visualization: The visualization tools in NX have been enhanced with advanced real-time shading and



rendering tools that deliver new levels of realism for aesthetic design review and validation. A new task environment provides access to all visualization tools in one place to help you more easily create high-quality images with the effects of image-based lighting, system scenes, and advanced material shading. Advanced ambient shadows consider the ambient lighting of the entire scene instead of a single light source, adding depth to the model to help improve perception of 3D shapes.

Drafting: NX 8 drafting tools have been enhanced with a set of commands for creating and editing your own custom drawings templates. You can create and edit associative borders and zones for each drawing sheet in the template file, construct and modify custom title blocks, create and link template regions, associate notes, tables, symbols and view with drawing regions, create re-usable drawing templates from the current drafting part, and apply Knowledge Fusion-based rules to govern behavior of objects in the template when it is inserted into another part.

A new tool for creating broken views in drawings enables you to easily add multiple horizontal or vertical breaks to a view, allowing more compact views to be drawn on the sheet that omit some geometry. Drafting and PMI now support standard fonts including TrueType, OpenType and PostScript, enabling you to replace, enhance, or supplement available character fonts.

NX help documentation The current release features a new look and feel and navigational aids for NX documentation. The new user interface makes it easier to find information and browse contents. Search performance is improved, and search is more easily accessible at the top of the Help window. The documentation has been reorganized to increase relevance of search results and to make navigation more logical and intuitive. Breadcrumb links atop each page help keep track of location. Links to all related information are displayed on each page.

NX 8 for simulation productivity

Drastically reduce the time you spend preparing and solving analysis models by up to 70 percent. Siemens has strengthened and expanded upon the technologies from its long simulation legacy and has brought them together to form NX CAE, a modern and integrated high-end analysis environment, and NX Nastran, a premium finite element solver. NX 8 introduces over 200 new capabilities to both NX CAE and NX Nastran that enable you to rapidly build, update and simulate analysis models, make smarter engineering decisions and deliver better products faster.

NX 8 CAE

NX CAE is a modern simulation environment that delivers all the advanced meshing, boundary conditions and solver interfaces that experienced analysts expect for high-end analysis.

What makes NX CAE unique from all other pre-processors is how it integrates a superior geometry foundation that enables intuitive geometry editing and analysis model associativity to multi-CAD data. Integrated multi-discipline solvers and multi-CAE solver support means analysts can more efficiently conduct all of their simulations from a single environment and eliminate data translation errors.

For NX 8, NX CAE introduces enhancements in the following key areas:

Simulation environment and geometry foundation

Creating a Face from an Existing Mesh:

Creating a face from an existing mesh helps analysts when they need to modify finite element models that either have no geometry (such as with imported legacy bulk data files) or meshes which are not associated to geometry. Creating a face from mesh is helpful when you need to associate an existing finite element model to new geometry, connect shell meshes or locally refine a region of a mesh that is not associated with any geometry.

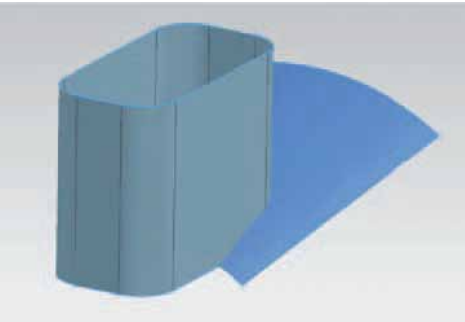
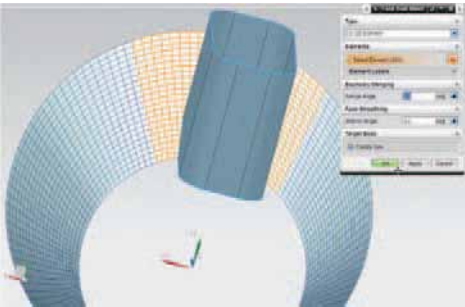

Suppressing Holes in Sheet Bodies:

This is used in cases where an analyst may want to ignore holes that do not contribute to the model's structural behavior. Suppressing the holes eliminates unnecessary mesh density in those regions. The new Suppress Hole command can remove holes from sheet bodies, such as mid-surface sheet bodies, defined through manually selecting holes or by holes with diameter smaller than a specified value.

Surface wrap fluid domain: Surface wrapping helps you to easily create fluid domain geometry used for CFD analysis from complicated models, such as for air volume of models that comprise many solid parts and complicated geometry. The surface wrapping algorithm creates an airtight envelope based on the selected bodies that define its surface boundaries and embedded bodies.

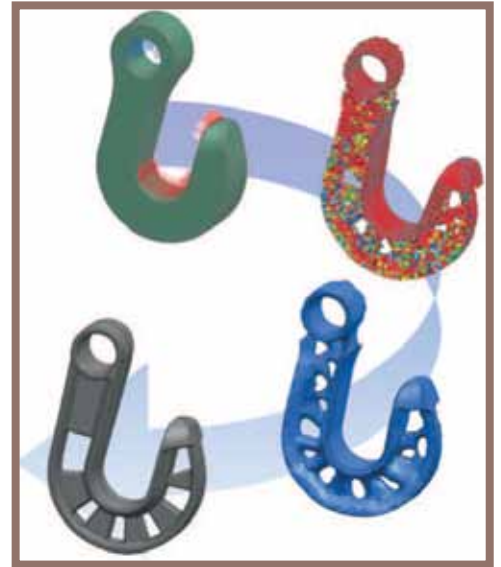
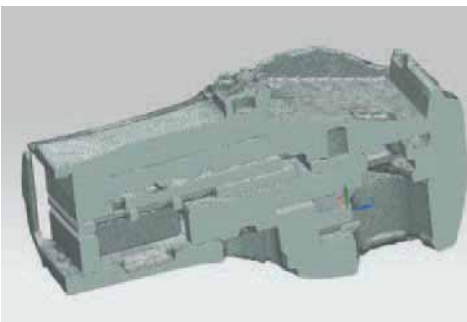
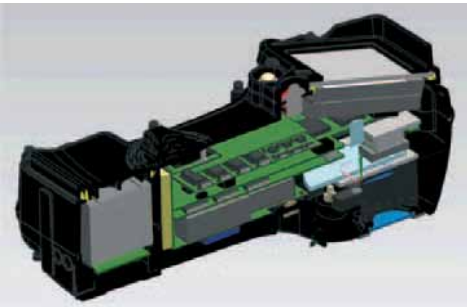

Multi-discipline simulation and optimization

Topology optimization: Bring simulation to the earliest stage of conceptual design. Topology optimization helps analysts reduce component weight by computing a conceptual optimal design based on a finite element model of the design space and loading conditions. Integration in the NX environment allows easy collaboration between analysts and designers because the conceptual design can seamlessly be handed to designers for further refinement.

Multi-physics thermo-mechanical analysis: Use multi-physics thermo-mechanical analysis to analyze thermal contact problems that will also have impact on structural performance, such as in aero engine design. The thermo-mechanical analysis is done by coupling an NX Thermal solution with an NX Nastran 101 solution for linear statics analysis. Coupling is made easy within the integrated environment and eliminates data transfer errors.

Systems-level simulation

External superelement system modeling:

Assembly FEM now allows analysts to build, solve, and post-process system models using external superelements. Using external superelements, analysts can reduce the number of DOFs (and consequently the number of equations) to a manageable number in a large system model. In addition, simplified representation of the geometry adds an extra layer of security for OEMs who do not wish to share full geometry details with third-party suppliers.

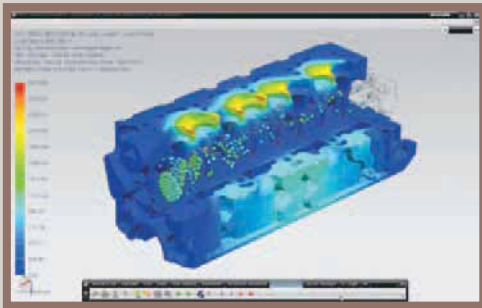

Parallel processing for flow analysis:

Parallel processing speeds solution times for large models. Distributed memory parallel (DMP) computing spreads large CFD simulations over a number of processors to speed solution time by 10 to 20 times.

HD-PLM

Results measures:

NX CAE introduces results measures which can be used to link simulation results to specific product requirements. After solving a model, analysts can identify specific result quantities as named expressions. For example, an analyst can create an expression that contains the value of von Mises stress from the specified subcase in the solution. This expression can then be linked to product requirements stored within Teamcenter, so project managers can easily be alerted to any cases where requirements are not being met.

NX Nastran 8: For over 40 years, Nastran has been an industry standard finite element solver for stress, vibration, structural failure, heat transfer, acoustics and aeroelasticity analyses. Major manufacturers worldwide rely on NX Nastran for their critical engineering computing needs to produce safe, reliable and optimized designs within increasingly shorter design cycle times.



NX Nastran 8 introduces Numerous Enhancements in the following Key Areas:

Discipline and physical domain extension

Easier coupling between NX Nastran and NX Thermal: The new multi-physics thermo-mechanical analysis capabilities, noted for NX CAE, further simplify the workflow to couple NX Nastran with NX Thermal.

Non-linear analysis material and loading extensions: New non-linear analysis material properties and loading extensions allow you to simulate more material types for non-linear analysis. Examples include viscoelastic properties for both hyperelastic and non-hyperelastic materials, Mullins effect with hyperelastic material, and combined creep with elastic/plastic strain.

Rotor dynamics: Rotor dynamics is used for analysis of rotating machinery and enables analysis of generic, symmetric and unsymmetric rotating structures in both fixed and rotating reference systems. The capability provides critical speed and stability analyses, frequency and transient response computations, both in direct and modal approaches.

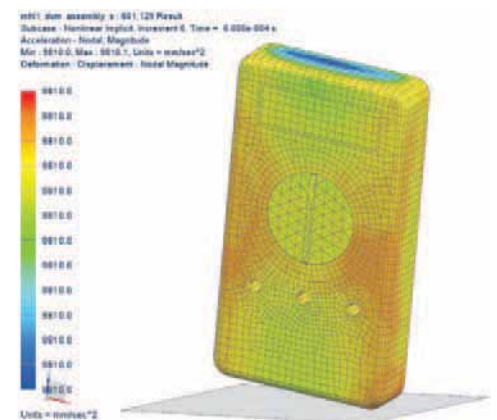

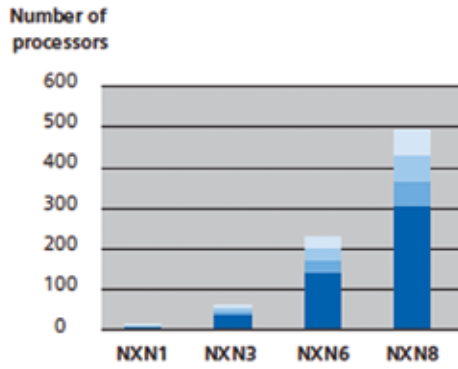
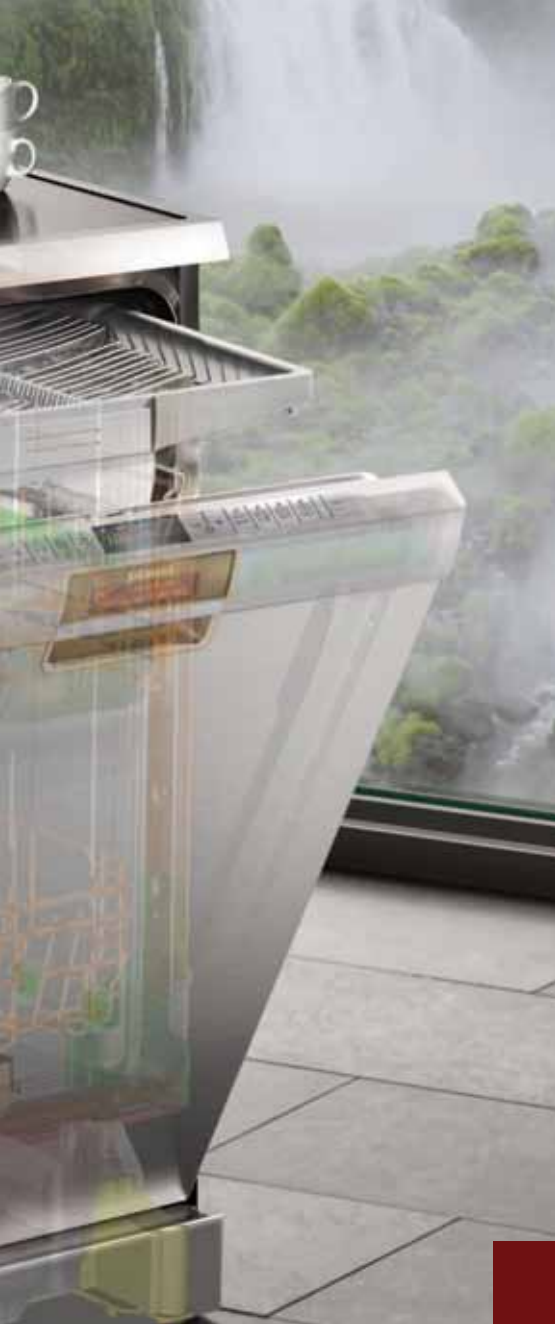

Computational performance and numerical accuracy

Parallel computing scalability improvements: Improvements in NX Nastran 8 for parallel processing increase SMP (shared memory parallel) processing performance and address frequency response optimization for DMP (distributed memory parallel) processing.

RDModes extension to more solution types: NX Nastran 8 extends the RDModes performance acceleration to the modal transient response solution (SOL 112) and modal analysis with optimization solution (SOL 200). RDModes also now supports restarts when using SOL 103, 111 and 112.

Ease of modeling and engineering workflow

Connection improvements: Connections greatly simplify the FE modeling process. NX Nastran's contact mechanisms have been extended to include special cases such as edge-to-edge and edge-to-surface contacts. Loads carried by glue connections can also be viewed in a post processor.

New composite solid element: The new composite solid element gives a more geometrically precise representation of a pyramid element support for hyperelastic materials and easier material coordinate system definitions for solid elements.

Superelement improvements: NX Nastran 8 composite material. This new element is just one of many

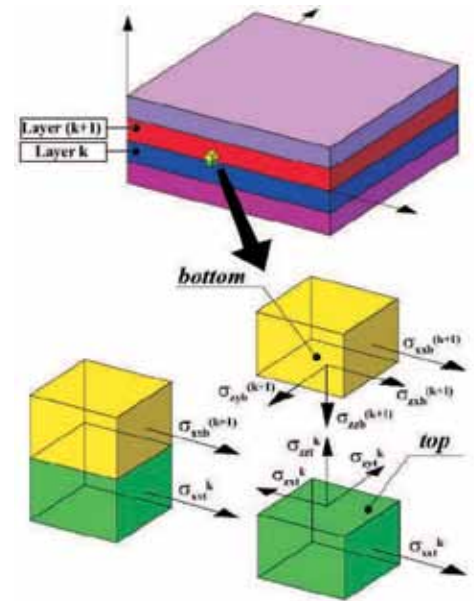

element improvements introduced in NX Nastran 8 including includes improvements to super elements so that NX CAE users can easily use external superelements in the context of an NX CAE assembly FEM.

Optimization improvements: Optimization improvements have been made to bushing and beam design variables and design cycle data block outputs to support frequency dependent properties, increase optimization accuracy, and display more optimization results.

Dynamics improvements: NX Nastran 8 includes improvements to its dynamics solutions to improve accuracy or extend capabilities in the following areas:

- Residual Vector
- Transient Initial Conditions (SOL 109/112)
- Modal Contributions
- Panel Contributions
- Flexible Body Export
- Frequency Dependent Stiffness
- NX Response Simulation Support
- Static Condensation

NX 8 for manufacturing productivity

NX CAM

Redefine manufacturing productivity for machinery parts with NX 8: NX CAM redefines manufacturing productivity with a full range of NC programming capabilities optimized for machinery parts. Advanced programming capabilities that are necessary for machinery parts are available with milling, drilling, turning, mill-turn and wire EDM applications. And with NX 8, new processors provide the most efficient approach for programming prismatic features like holes, slots and pockets. The milling, turning and mill-turn functions are enhanced with stock-sensitive tracking of the in-process work piece to make machinery part programming fast and simple.

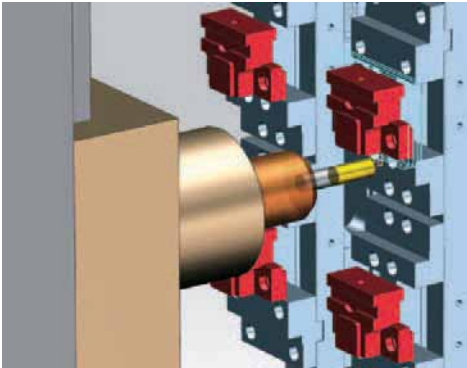

Volume based 2.5 axis milling:

Traditional 2.5 axis milling is more intuitive and more productive than ever with the new selection approach in NX 8 CAM. Cutting volumes are quickly identified based on floor and wall selections. These floors and walls in combination with the in-process work piece (blank stock) result in volumetric cut regions.

- Floor cuts have multiple depths as necessary for the in-process stock
- Wall cuts have multiple passes as necessary for the in-process stock

- Cuts use the in-process work piece at all times to eliminate air cuts.
- The uncut in-process material is shown in a persistent display, with cut regions also displayed before generating tool path.

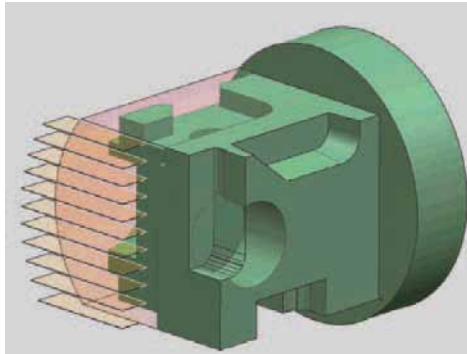

In-process work piece flow across setups:

NX 8 CAM automatically transfers in-process work piece models from one setup to the next. You can use any initial blank definition, and then let it follow the part component from one position to another. The in-process blank component automatically inherits the assembly positioning from the underlying part.

- Associativity and update mechanisms work across setups
- Assembly configurations are supported in Teamcenter

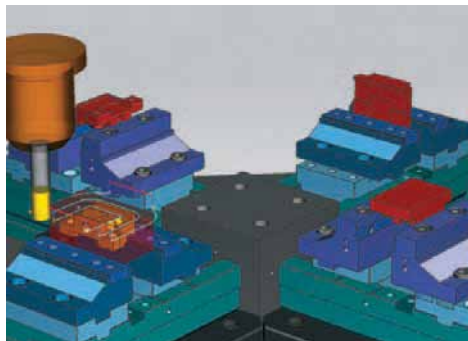

Hole/boss milling: Holes and bosses get special handling in NX 8 CAM for optimum milling. Geometry selection supports both manual and feature based operation types.

Hole/boss milling operations include specific cutting and non-cutting motions:

- Approach features from multiple vectors
- Apply safe traverse connections between features
- True spiral down patterns for finishing
- True spiral out patterns for roughing
- Spiral down then out for multi-level roughing

Additionally, internal and external thread milling, including tapered threads, is supported. Multiple thread definitions are provided:

- Manual
- From table, including NPT, BSTP, etc.
- From tool
- Inferred from model (CAD feature and/or symbolic thread)

Continued CAM leadership : NX™ CAM continues to lead the NC programming industry with top capabilities across key industries and machine tool technologies with the release of version 8. New 5 axis functionality makes it easier than ever to gain the benefits of 5 axis machining, even in mold and die applications. And new specialized methods are provided for machining turbomachinery components with NX 8 CAM.

Feature-based machining (FBM)

customization: NX 8 CAM takes FBM to the next level with interactive development of feature and process definitions that provide faster customizations. With the new Teach Features function you can define custom feature types interactively, in the graphics environment. Feature recognition then interprets the XML feature definitions dynamically, including the custom features.

Additionally, with the new Teach Operations function you can easily build up machining process definitions from NX CAM operations and identify process specific parameters such as cutting, non-cutting, user-defined events (UDEs), cycles, and cycle parameters, cut levels and KF parameters. Then optionally edit machining rules in the Machining Knowledge Editor (MKE) to make them more general.

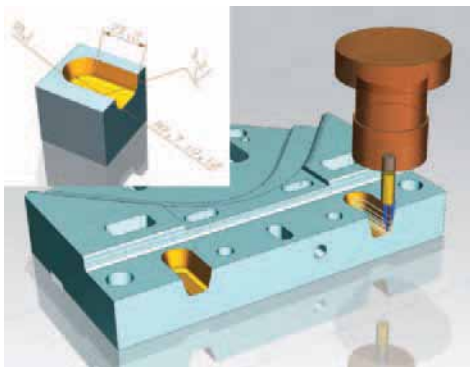

Tool path tilt: The flexibility of 5 axis milling can be easily applied to traditional 3 axis applications. Instead of requiring longer tools to reach deep into cavities, NX 8 allows cuts to be programmed with shorter tools, then automatically tilts the tool axis as necessary to avoid holder interference as deeper regions are cut. This provides

significant benefits in cutting speed, tool life, and surface quality.

Turbomachinery milling: With version 8, NX extends its capabilities for multi-bladed turbines and blisks with additional cutting methods:

- New blend finish operation
- Helical blade finishing for superior finishes
- Advanced multi-level synchronization of points ensures the smoothest finishes.
- Tool axis is interpolated automatically, with available manual control at any point. Interpolated orientations are previewed when manipulating the tool axis, showing any unsafe regions where NX will automatically tilt to keep a smooth gouge-free path.

Dynamic tool axis control: The NX tool display includes interactive grab handles. You can display the entire machine assembly while dragging the tool to see how the machine is positioned for any tool location. Collisions and machine axis limits are highlighted. This full-context information is available when setting the tool axis interactively or when editing tool parameters.

Shop documentation: You can send NC program and tool information to the shop floor with easily edited templates. Send the entire setup or selected operations. Templates are customized in Excel, so no knowledge of TCL or MOM programming is required to output custom sheets with:

- Page content length
- Repeat title
- Tool and operation tables

- Graphics
- Part attributes
- Over 1000 MOM variables

NC simulation and Virtual Machine:

The Virtual Machine is the highest level of NC simulation, providing the best possible language support, cycle support, and motion accuracy for proving out NC programs. It uses Siemens' Virtual NC Kernel (VNCK) to replicate every aspect of Sinumerik control behavior. NX 8 CAM provides support for the latest VNCK version with support for 840D Solutionline and Powerline models. Both spinning and non-spinning tools are supported and performance is improved across all simulation environments.

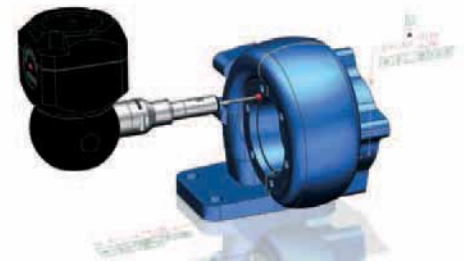

NX CMM inspection programming

Inspection programming within NX takes a major step forward with NX 8 and is the first to achieve DMIS 5.2 certification. Quality measurements can be driven by the embedded product manufacturing information (PMI). And more complex measurement motion chains can be developed.

PMI integration: CMM programs now takes full advantage of the embedded PMI information included in NX. PMI includes GD&T and 3D annotation information that provides the all-important manufacturing tolerances that inspection programs must verify.

Now you can take advantage of the existing PMI content in the NX models to drive programming, ensuring that the requested tolerances are measured against the designer's specification.

Multi-feature path creation: NX CMM Inspection Programming has expanded the links and connectivity options between individual measurements so that multiple features can be inspected in a single measurement task.

Collision avoidance: You can create collision-free paths between inspection operations, including operations driven by PMI and multi-feature paths. These inter-operation collision checks are in addition to the solids-based operations themselves, which are always checked.

Certification: NX is the first product to be certified against the latest Dimensional Measuring Standards Consortium standards for CMM programming, DMIS 5.2. DMIS is and continues to be the only international standard (DMIS version 4.0 is an ISO standard) for quality measurement information exchange.

NX tooling and fixture design

NX continues to provide industry-leading, comprehensive tools for the design of complete tooling systems for makers of molds, progressive dies and stamping dies.

Improved mold design: NX 8 reduces the time required to design and validate molds. The enhanced HD3D visualization tool for molded part validation helps part and tool designers find and correct a more extensive range of manufacturability issues that include: wall thickness, parting, pocket, overlapping surfaces, body boundaries and electrodes. You can even add your own custom checks.

The enhanced cooling circuit design tool displays flow direction and automates attachment of fittings to assist you in completing circuit design more quickly.

The new knowledge reuse library for standard parts and mold bases provides faster lookup and design insertion. Adding standard parts to a design is as easy as drag-and-drop. The library content includes the latest available supplier catalog data. And you can easily add your own content.

Improved progressive die design: NX 8 delivers new capabilities to slash your design time and help you to hit cost targets. The new Quick Quotation tool calculates cost directly from your 3D design data and burden rates. By integrating your actual 3D design with a costing spreadsheet you now have the ability to track tool costs as your design progresses through to completion.

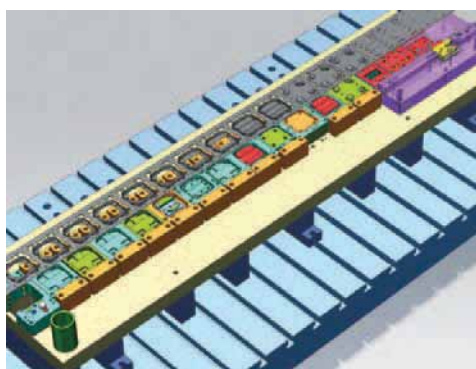
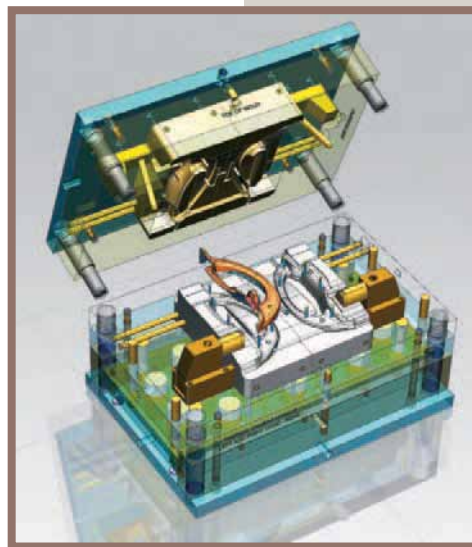

The new knowledge reuse library for standard parts and die bases provides faster lookup and design insertion. Adding a standard part to a design is as easy as drag-and-drop and the library includes the latest available supplier catalog content.

You can reduce your overall design time by working concurrently with multiple designers on the same tool. Concurrent design workflow management lets you assign designers to specific modules of the tool and keeps the project data organized.

Change-over management assists you in creating new die designs for families of parts. For example, after you design a die set for right-handed part, you can use change-over management to automate the creation of a left-handed die set.

New engineering die design workflow: NX 8 introduces a new workflow that automates the process of designing transfer and tandem dies. The new workflow guides you through the process of designing each die station with specialized tools for piercing, trimming, punch, forming and die inserts. For transfer dies, die sets are mounted to a single press machine. Die sets are individually mounted to separate presses for tandem dies.

Material transfer equipment can be added from a library. Motion simulation is used to verify that the part transfer and die sequencing perform correctly. Automatically create the parts list and drawings directly from the 3D solids tool model.

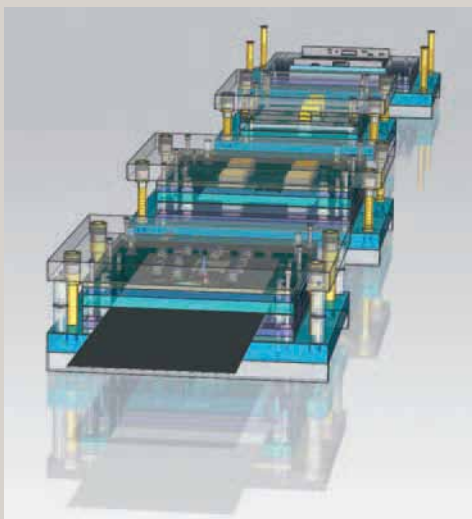

Improved stamping die design: NX 8 delivers new capabilities that increase die development productivity. The new knowledge reuse library for standard parts and die bases provides faster lookup and drag-and-drop design insertion for die components. A new set of piercing inserts has also been added to the library.

The die face design module is enhanced to improve design productivity. Ensure trim angles follow manufacturing specifications with an automated visual check. Re-use standard addendum sections from the library and control section parameters. Accelerate detailed draw punch and die design using specialized features such as ribs and keyways.

Automate downstream NC programming processes by attaching PMI (Product Manufacturing Information) to die faces. Faces can be tagged for specific machining operations which NX CAM can use to automate creation of machining operations and tools.

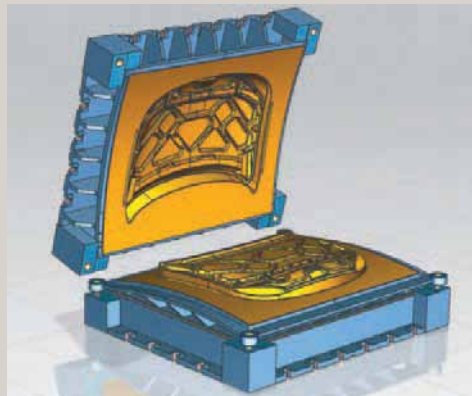

NX

Leading CAD/CAM/CAE maximizes product development productivity and helps you get the right product to market faster than ever before

Key Benefits of NX 8:

- More productive product development
- Better product quality, faster development, lower costs
- More informed decision making
- Faster, more efficient modeling
- Better compliance with standards and product requirements
- Up to 70 percent reduction in simulation modeling and solution time
- More analysis solutions for optimization and multi-physics
- More productive NC programming for machinery parts
- Faster, more efficient tooling design

Call Swoosh Technologies Toll free today to learn how NX 8 will benefit your company.
(888) 318-5104

Or visit online at
WWW.SWOOSHTECH.COM



SUCCESS WITH NX

Ducati Motor Holdings

NX and Teamcenter play a key role in Ducati's development process.



"NX is the tool we use from the moment we start thinking about a new project up to its completion."

"NX is used to design many different motorbike components, including the wheels, the chassis and the body, as well as custom parts – virtually everything except the engine."

"Our design and development cycle has been cut from an average 36 to 40 months to just 24, mainly thanks to the tools provided by Siemens PLM Software."

*Piero Giusti
Information Technology Manager for
R&D at Ducati Motor Holding*



Ducati has more than 50 NX workstations, with plans to add more.



Dali & Samir Engineering Pvt. Ltd.

“NX has enabled us to shrink the time needed to design a new tool – from 4 days in the past to 2 days today. We’ve also seen our product development costs drop by 25 percent. The improvements made possible using NX position us to achieve our goal of becoming an OEM’s first choice when it comes to exhaust systems and other sheet metal components. Looking at the emerging market scenario, we want to enhance our core competency in the fabrication of sophisticated engineering products, especially in the automotive area. NX is playing an important role in our ability to accomplish this.”

*Shivaji Powar
Manager of Design
Dali & Samir
Engineering Pvt. Ltd.*

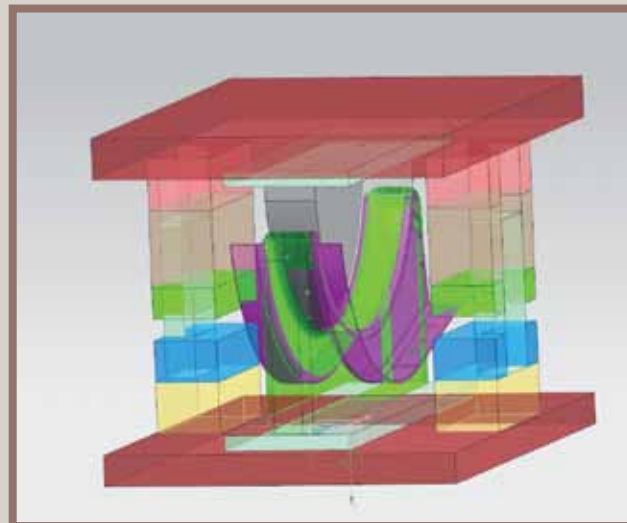
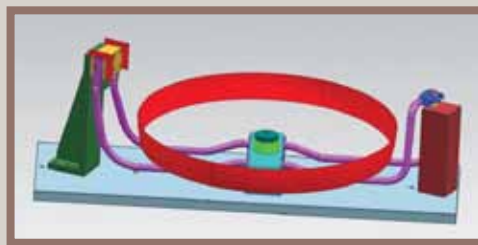
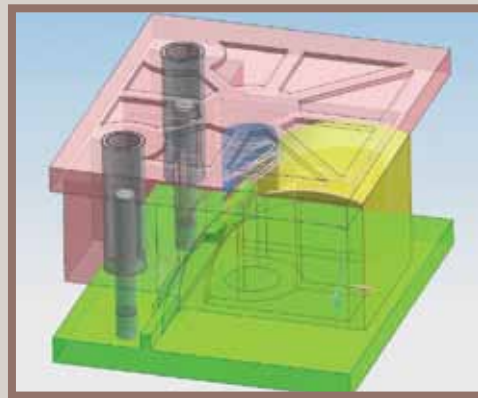

Key Improvements in NX 8:

Design productivity:

- High definition 3D for better product decisions
- Powerful design creation and editing with the
- 4th release of Siemens’ breakthrough synchronous technology

Simulation productivity:

- Advanced technology for CAE modeling
- New capabilities for topology optimization
- Powerful new tools for systems-level simulation
- New capabilities that link CAE results to product requirements

Manufacturing productivity:

- Optimized NC programming for tooling and component machining
- Faster design of injection molds and sheet metal dies



Swoosh Technologies & Solutions: Swoosh Technologies PLM has a long legacy of working in the fields of aerospace, automotive, off-road vehicles, and machinery design to leverage PLM solutions that help companies achieve business objectives of quality improvement, waste reduction, shorter cycle times and increased product innovation.

Swoosh Technologies Educational Services: delivers complete product training for Solid Edge, NX Product Design & NX Manufacturing (basic to advanced full 5-axis), Teamcenter Engineering and Teamcenter Express. We offer off-site training at one of our three locations or on-site training at your destination. Our courseware is developed in-house and targeted specifically for your design and manufacturing requirements.

Swoosh Technologies Solutions Partners: Siemens PLM delivers world class solutions with the power of Synchronous Technology (ST). Solid Edge with ST is changing the way products are designed. Design it once, change it forever.

WWW.SWOOSHTECH.COM

TOLL FREE: (888) 318-5104

DIRECT: (314) 549-8110